



FM4442

256 Bytes Memory Card Chip

Specification

Oct. 2007

INFORMATION IN THIS DOCUMENT IS INTENDED AS A REFERENCE TO ASSIST OUR CUSTOMERS IN THE SELECTION OF SHANGHAI FUDAN MICROELECTRONICS CO., LTD PRODUCT BEST SUITED TO THE CUSTOMER'S APPLICATION; THEY DO NOT CONVEY ANY LICENSE UNDER ANY INTELLECTUAL PROPERTY RIGHTS, OR ANY OTHER RIGHTS, BELONGING TO SHANGHAI FUDAN MICROELECTRONICS CO., LTD OR A THIRD PARTY. WHEN USING THE INFORMATION CONTAINED IN THIS DOCUMENTS, PLEASE BE SURE TO EVALUATE ALL INFORMATION AS A TOTAL SYSTEM BEFORE MAKING A FINAL DECISION ON THE APPLICABILITY OF THE INFORMATION AND PRODUCTS. SHANGHAI FUDAN MICROELECTRONICS CO., LTD ASSUMES NO RESPONSIBILITY FOR ANY DAMAGE, LIABILITY OR OTHER LOSS RESULTING FROM THE INFORMATION CONTAINED HEREIN. SHANGHAI FUDAN MICROELECTRONICS CO., LTD PRODUCTS ARE NOT INTENDED FOR USE IN MEDICAL, LIFE SAVING, OR LIFE SUSTAINING APPLICATIONS. THE PRIOR WRITTEN APPROVAL OF SHANGHAI FUDAN MICROELECTRONICS CO., LTD IS NECESSARY TO REPRINT OR REPRODUCE IN WHOLE OR IN PART THESE DOCUMENTS.

Future routine revisions will occur when appropriate, without notice. Contact Shanghai Fudan Microelectronics Co., Ltd sales office to obtain the latest specifications and before placing your product order. Please also pay attention to information published by Shanghai Fudan Microelectronics Co., Ltd by various means, including Shanghai Fudan Microelectronics Co., Ltd home page (<http://www.fmsh.com/>).

Please contact Shanghai Fudan Microelectronics Co., Ltd local sales office for the specification regarding the information in this documents or Shanghai Fudan Microelectronics Co., Ltd products.

Trademarks

Shanghai Fudan Microelectronics Co., Ltd name and logo, the “复旦” logo are trademarks or registered trademarks of Shanghai Fudan Microelectronics Co., Ltd or its subsidiaries in China.

Shanghai Fudan Microelectronics Co., Ltd, Printed in the China, All Rights Reserved.

Product Overview

Description

FM4442 is the memory card chip developed by Shanghai FM Co., Ltd. This chip uses 0.6 μ m CMOS EEPROM process, has 256 \times 8 Bits EEPROM with write protect function and programmable security code. With its contact configuration in accordance to ISO standard 7816 (synchronous transmission), FM4442 can be widely used in different types of IC memory cards.

Features

- 256 \times 8-bits EEPROM organization;
- Byte-wise addressing
- Irreversible byte-wise write protection
- Irreversible byte-wise write protection of lowest 32 addresses (Byte 0 ... 31)
- Minimum of 100000 write/erase cycles
- Data retention for minimum of ten years
- Contact configuration and serial interface in accordance with ISO standard 7816 (synchronous transmission)
- Only after entry of the correct 3Bytes programmable security code (PSC)
- Compatible SLE4442

Pin Assignment

VCC	C1		C6	GND
RST	C2		C5	NC
CLK	C3		C4	I/O

Pin Function

Pin	symbol	Function
C1	VCC	Supply voltage 2.7V ~ 5V
C2	RST	Reset
C3	CLK	Clock input
C4	I/O	Bidirectional data line (open drain)
C5	NC	Not Connected
C6	GND	Ground

Function Description

The FM4442 consists of 256 x 8 bits EEPROM main memory and a 32-bit protection memory with PROM functionality. The main memory is erased and written byte by byte. Each of the first 32 bytes can be irreversibly protected against data change by writing the corresponding bit in the protection memory. Each data byte in this address range is assigned to one bit of the protection memory and has the same address as the data byte in the main memory which it is assigned to. Once written the protection bit cannot be erased (PROM).

Reset and Answer-to-Reset

Answer-to-Reset takes place according to ISO standard 7816-3 (ATR). The reset can be given at any time during operation. In the beginning, the address counter is set to zero together with a clock pulse and the first data bit (LSB) is output to I/O when RST is set from level H to level L. Under a continuous input of additional 31 clock pulses the contents of the first 4 EEPROM addresses is read out. The 33rd clock pulse switches I/O to high impedance Z and finishes the ATR procedure.

Answer-to-Reset	Byte1	Byte 2	Byte 3	Byte 4
(HEX)	DO ₇ ...DO ₀	DO ₁₅ ...DO ₈	DO ₂₃ ...DO ₁₆	DO ₃₁ ...DO ₂₄

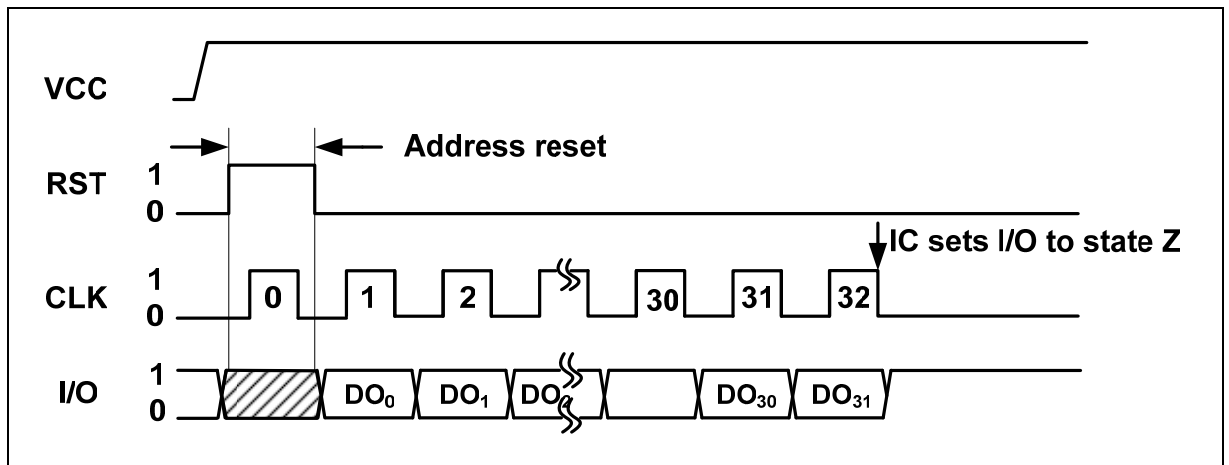

Figure 1 Reset and Answer-to-Reset

Commands

Commands Format:

MSB			Control				LSB			MSB			Address					LSB			MSB			Data				LSB		
B7	B6	B5	B4	B3	B2	B1	B0	B7	B6	B5	A7	A6	A5	A4	A3	A2	A1	A0	D7	D6	D5	D4	D3	D2	D1	D0				

Command Introduction

(1) Read Main Memory

	Control								Address	Data
	B7	B6	B5	B4	B3	B2	B1	B0	A7...A0	D7...D0
Binary	0	0	1	1	0	0	0	0	Address	No effect
Hexadecimal	30 _H								00 _H ...FF _H	No effect

The command reads out the contents of the main memory (with LSB first) starting at the given byte address ($N = 0 \dots 255$) up to the end of the memory. After the command entry the IFD has to supply sufficient clock pulses. The number of clocks is $m = (256 - N) \times 8 + 1$. The read access to the main memory is always possible.

(2) Read Protection Memory

	Control								Address	Data
	B7	B6	B5	B4	B3	B2	B1	B0	A7...A0	D7...D0
Binary	0	0	1	1	0	1	0	0	No effect	No effect
Hexadecimal	34 _H								No effect	No effect

The command transfers the protection bits under a continuous input of 32 clock pulses to the output. I/O is switched to high impedance Z by an additional pulse. The protection memory can always be read, and indicates the data bytes of the main memory protected against changing.

(3) Update Main Memory

	Control								Address	Data
	B7	B6	B5	B4	B3	B2	B1	B0	A7...A0	D7...D0
Binary	0	0	1	1	1	0	0	0	Address	Input data
Hexadecimal	38 _H								00 _H ...FF _H	Input data

The command programs the addressed EEPROM byte with the data byte transmitted. Depending on the old and new data, one of the following sequences will take place during the processing mode:

- erase and write (5 ms) corresponding to $m = 245$ clock pulses
- write without erase (2.5 ms) corresponding to $m = 124$ clock pulses
- erase without write (2.5 ms) corresponding to $m = 124$ clock pulses

(All values at 50 kHz clock rate.)

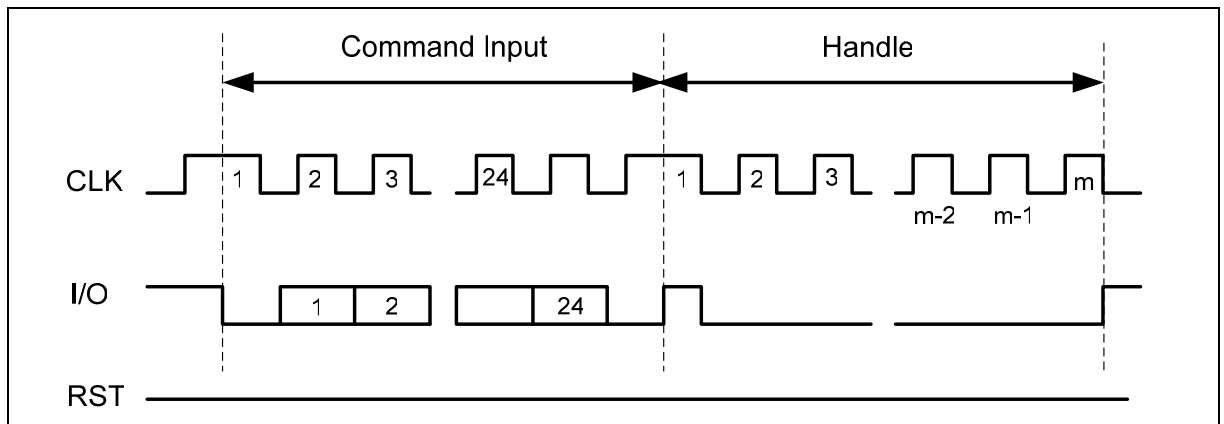

Figure 2 Update main memory

(4) Write Protection Memory

	Control								Address	Data
	B7	B6	B5	B4	B3	B2	B1	B0	A7...A0	D7...D0
Binary	0	0	1	1	1	1	0	0	Address	Input data
Hexadecimal	30 _H								00 _H ...FF _H	Input data

The execution of this command contains a comparison of the entered data byte with the assigned byte in the EEPROM. In case of identity the protection bit is written thus making the data information unchangeable. If the data comparison results in data differences writing of the protection bit will be suppressed.

(5) Read Security Memory

	Control								Address	Data
	B7	B6	B5	B4	B3	B2	B1	B0	A7...A0	D7...D0
Binary	0	0	1	1	0	0	0	1	No effect	No effect
Hexadecimal	31 _H								No effect	No effect

Similar to the read command for the protection memory this command reads out the 4 bytes of the security memory.

(6) Update Security Memory

	Control								Address	Data
	B7	B6	B5	B4	B3	B2	B1	B0	A7...A0	D7...D0
Binary	0	0	1	1	1	0	0	1	Address	Input data
Hexadecimal	39 _H								00 _H ...FF _H	Input data

Regarding the reference data bytes this command will only be executed if a PSC has been successfully verified before. Otherwise only each bit of the error counter (Address 0) can be written from "1" to "0". The execution times and the required clock pulses are the same as described under update main memory.

(7) Compare Verification Data

	Control								Address	Data
	B7	B6	B5	B4	B3	B2	B1	B0	A7...A0	D7...D0
Binary	0	0	1	1	0	0	1	1	Address	Input data
Hexadecimal	33 _H								00 _H ...FF _H	Input data

The command compares one byte of the entered verification data byte with the corresponding reference data byte.

PSC Verification

The FM4442 requires a correct verification of the Programmable Security Code PSC stored in the Security Memory for altering data if desired. The following table gives an overview of the necessary commands for the PSC verification. The sequence of the shaded commands is mandatory.

Command	Control	Address	Data	Remark
	B7...B0	A7...A0	D7...D0	
Read security memory	31 _H	No effect	No effect	Check error counter
Update security memory	39 _H	00 _H	Input data	Write free bit in error counter input data: 0000 0ddd binary
Compare verification data	33 _H	01 _H	Input data	Reference data byte1
Compare verification data	33 _H	02 _H	Input data	Reference data byte2
Compare verification data	33 _H	03 _H	Input data	Reference data byte3
Update security memory	39 _H	00 _H	FF _H	Erase error counter
Read security memory	31 _H	No effect	No effect	Check error counter

Electrical Characteristics

Absolute Maximum Ratings

Parameter	Symbol	Min.	Typ.	Max.	Unit
Supply Voltage	V_{CC}	-0.3	-	6	V
Input voltage	V_i	-0.3	-	6	V
Storage temperature	T_{sto}	-40	-	+125	°C
Power dissipation	P_{tot}	-	-	60	mW

Operation Range

Parameter	Symbol	Min.	Typ.	Max.	Unit
Ambient temperature	T_A	-35	-	+100	°C

DC Characteristics

Parameter	Symbol	Min.	Typ.	Max.	Unit
supply voltage	V_{CC}	4.5	5	5.5	V
Supply current	I_{CC}	-	3	10	mA
High level input voltage (I/O, CLK, RST)	V_{ih}	0.7 V_{CC}	-	V_{CC}	V
Low level input voltage (I/O, CLK, RST)	V_{il}	0	-	0.8	V
High level input current (I/O, CLK, RST)	I_h	-	-	50	μA
Low level output current ($V_{OL} = 0.4V$, open drain)	I_{ol}	1	-	-	mA
High level output current ($V_{OH} = 5V$, open drain)	I_{oh}	-	-	50	μA
Input capacitance	C_i	-	-	10	pF
Test	f	-	20	-	KHz
supply voltage	T	Open or on GND			

AC Characteristics

Parameter	Symbol	Min.	Typ.	Max.	Unit
CLK Frequency	t_{RE}	9	-	-	μs
CLK High time	t_H	10	-	-	μs
CLK Low time	t_L	10	-	-	μs
CLK Rise time	t_W	2.5	-	-	ms
CLK Fall time	t_E	2.5	-	-	ms
I/O Low to CLK Hold time (Start Condition)	t_{d1}	4	-	-	μs
RST Low to I/O Valid time	t_{d3}	4	-	-	μs
CLK High to I/O Clear time	t_{d4}	4	-	-	μs
CLK Low to RST Hold time	t_{d5}	4	-	-	μs
CLK Low to I/O Hold time	t_{d2}	6	-	-	μs
RST High time (address reset)	t_R	-	-	1	μs
I/O Setup to CLK High time	t_F	-	-	1	μs

Ordering Information

Ordering code	Package	Product Carrier	Operation Range
FM4442-P5-01	Micro-Module Package (6Pin)	Reel	Industrial Temperature -20°C ~ +60°C
FM4442-P5-02	Micro-Module Package (6Pin)	Reel	
FM4442-M3	Micro-Module Package (6Pin)	Reel	

Revision History

Version	Publication date	Pages	Paragraph or Illustration	Revise Description
1.0	Oct. 2007	11		Initial Release.

Sales and Service

Shanghai Fudan Microelectronics Co., Ltd.

Address: Bldg No. 4, 127 Guotai Rd,
Shanghai City China.

Postcode: 200433

Tel: (86-21) 6565 5050

Fax: (86-21) 6565 9115

Shanghai Fudan Microelectronics (HK) Co., Ltd.

Address: Flat 12, 7/F, East Ocean Centre, 98 Granville Rd,
Tsimshatsui East, Kowloon, Hong Kong.

Tel: (852) 2116 3288 2116 3338

Fax: (852) 2116 0882

Beijing Office

Address: Room.1208, Bldg C,
Zhongguancun Science and Technology Development Edifice,
34 zhongguancun Street (South),
Haidian District, Beijing City, China.

Tel: (86-10) 6212 0682 6213 9558

Fax: (86-10) 6212 0681

Shenzhen Office

Address: Room.1301, Century Bldg, Shengtingyuan Hotel, Huaqiang Rd (North),
Shenzhen City, China.

Postcode: 518028

Tel: (86-755) 8335 3211 8335 6511

Fax: (86-755) 8335 9011

Web Site: <http://www.fmsh.com/>